

PT 25P

Ideal Selection For Heavy Duty And Long Distance Transportation Operations With Fixed or Foldable Platform

INTRODUCTION

With its fixed or foldable platform the PT 25P is designed to meet the requirement of high duty transportation operations on long distances and higher travelling speed.

The fixed , very Spacious , safe and ergonomic platform is the first choice for intra-logisitc transportation on long distances , where on the foldable platform is space saving in narrow aisle .



AUTHORISED DEALER

Noblelift Europe GmbH

Add: Borsigstrasse 9, 93092 Barbing
Germany
TEL: +49 9401 607930
FAX: +49 9401 6079329
WEB: www.noblelifteurope.com
email: mail@noblelifteurope.com

NOBLELIFT

PT 25P

IDEAL SELECTION FOR HEAVY DUTY AND LONG DISTANCE TRANSPORTATION OPERATIONS WITH FIXED OR FOLDABLE PLATFORM



2500KG

ADVANTAGES

- Powerful high quality German AC drive unit.
- EPS-Electric steering system.
- High capacity 3PzS battery for long shifts.
- Sideways battery exchange compartment for quick and safe battery exchange.
- Robust and ergonomic design.
- Fixed platform or foldable platform with protective arms.



AC drive technology

Powerful high quality AC drive unit ensures high performance and low maintenance. On ramps the truck not rolls backwards.

High performance

High speed saves time and increases the handling capacity.

EPS- Electric steering system

The EPS supports the operator during the whole day and makes operations more effortless.

Ergonomic tiller and handholds

By travelling with the forks backside, one hand can ergonomically reach the grip, the other holds the tiller. For both left-handed and right-handed operators.



Control elements

Key-switch, emergency switch and battery discharge indicator.

Storage tray

Diverse storage areas for stretch foils, documents or clipboards, etc.



Sideways battery exchange

Sideways battery exchange compartment for quick and safe battery exchange. Because the battery compartment is lifted with the forks, various exchange heights are easy to reach.

Powerful battery

High performance 3PzS DIN-standard battery for long or multi shifts. The battery rollers minimize the forces for exchange. Exchange to the left or right side (selection).



Ergonomic design

Fixed or foldable platform with protective arms. The cushioned platforms ensure safety in all travelling conditions. Roomy, ergonomic and safe fixed platform with rubber bumper.



Foldable platform

Foldable platform for higher flexibility in narrow spaces.

Type sheet for industrial truck acc. to VDI 2198 1KG=2.2LB 1INCH=25.4MM

Distinguishing mark	1.2	Manufacturer's type designation		PT 25P	
				Fixed platform	Foldable platform
	1.3	Power(battery,diesel,petrol gas,manual)		Battery	
	1.4	Operator type		Stand	Pedestrian(Stand)
	1.5	Load Capacity / rated load	Q (t)	2.5	
	1.6	Load centre distance	c (mm)	600	
	1.8	Load distance, centre of drive axle to fork	x(mm)	965	
	1.9	Wheelbase	y (mm)	1595	
	Weight	2.1	Service weight	kg	1085
2.2		Axle loading, laden front/rear	kg	1555/2030	1370/2080
2.3		Axle loading, unladen front/ rear	kg	885/200	730/220
Tyres, chassis	3.1	Tires		Polyurethane (PU)	
	3.2	Tire size, front	Ø x w (mm)	Ø82X82	
	3.3	Tire size, rear	Ø x w (mm)	Ø250X82	
	3.4	Additional wheels (dimensions)	Ø x w (mm)	Ø124X60	
	3.5	Wheels, number front/ rear(x=driven wheels)		1×+2/4	
	3.6	Tread, front	b10 (mm)	530	
	3.7	Tread, rear	b11 (mm)	367/512	
Dimensions	4.4	Lift height	h3 (mm)	120	
	4.9	Height of tiller in drive position min. / max.	h14 (mm)	1235	1005/1445
	4.15	Height, lowered	h13 (mm)	85	
	4.19	Overall length	l1 (mm)	2667	2122
	4.20	Length to face of forks	l2 (mm)	1516	971
	4.21	Overall width	b1 (mm)	790	
	4.22	Fork dimensions	s/e/l (mm)	60/173/1150	
	4.25	Distance between fork-arms	b5 (mm)	540/685	
	4.32	Ground clearance, centre of wheelbase	m2 (mm)	25	
	4.33	Aisle width for pallets 1000 x 1200 crossways	Ast(mm)	3084	2550
	4.34	Aisle width for pallets 800X1200 lengthways	Ast (mm)	2945	2410
4.35	Turning radius	Wa (mm)	2520	1980	
Performance data	5.1	Travel speed, laden/ unladen	km/h	9/12	9.5/12.5
	5.2	Lift speed, laden/ unladen	m/s	0.038/0.058	
	5.3	Lowering speed, laden / unladen	m/s	0.050/0.048	
	5.8	Gradeability, laden/ unladen	%	8/10	8/15
	5.10	Service brake		Electromagnetic	
Electric- Motor	6.1	Drive motor rating S2 60min	kW	2.9	
	6.2	Lift motor rating at S3 10%	kW	2.2	
	6.3	Battery acc. to DIN 43531 /35 / 36 A, B, C, no		B, 3PzS	
	6.4	Battery voltage, nominal capacity K5	V/Ah	24/ 375	
	6.5	Battery weight (minimum)	kg	300	
	6.6	Energy consumption acc. to VDI cycle	kWh/h	1.83	1.75
Additional data	8.1	Type of drive control		AC- Speed Control	
	8.4	Sound level at driver's ear acc. to EN 12053	dB(A)	69	

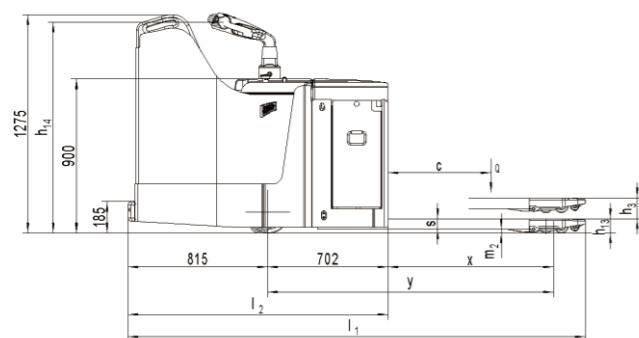

PT 25P Fixed

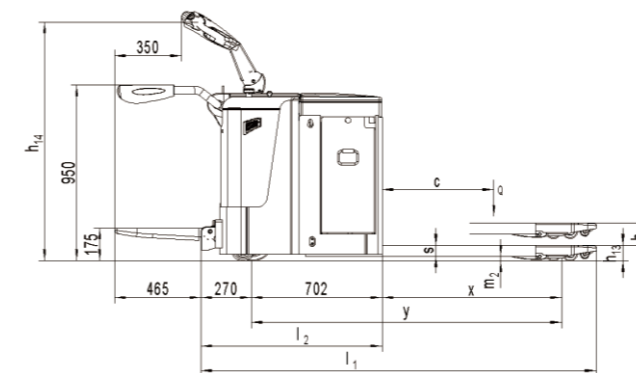
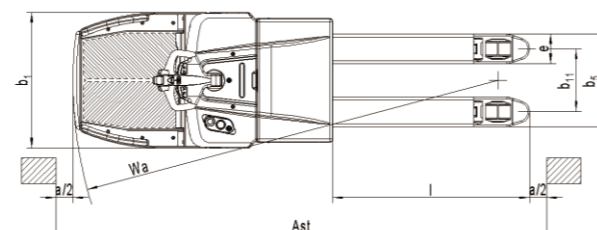

PT 25P Foldable

