

ELECTRIC VERTICAL MAST LIFT

# W V10 E



**AIRO**  
SAFELY, HIGHER.

MADE IN ITALY



## PERFORMANCES

The concept of the machine, despite its small dimensions, allows it to combine capacity and height: up to 10 metres in height, with a platform load of 200 kg, the V10 model makes the most of the lateral outreach by offering a up and over point that is variable in height.

## ADVANTAGES

The small footprint of the undercarriage, the possibility of moving and rotating the turret simultaneously, and the presence of one joystick for each movement make the V10E model the ideal ally for work at height and passageways in confined spaces. Thanks to its battery power supply, the possibility of exploiting an excellent lateral outreach of up to 3.3 metres, this model is typically used in logistics and all industrial maintenance works.

## VALUE

40 years of experience in design and manufacturing are a guarantee of reliability and durability.



# V10 E



## Technical data

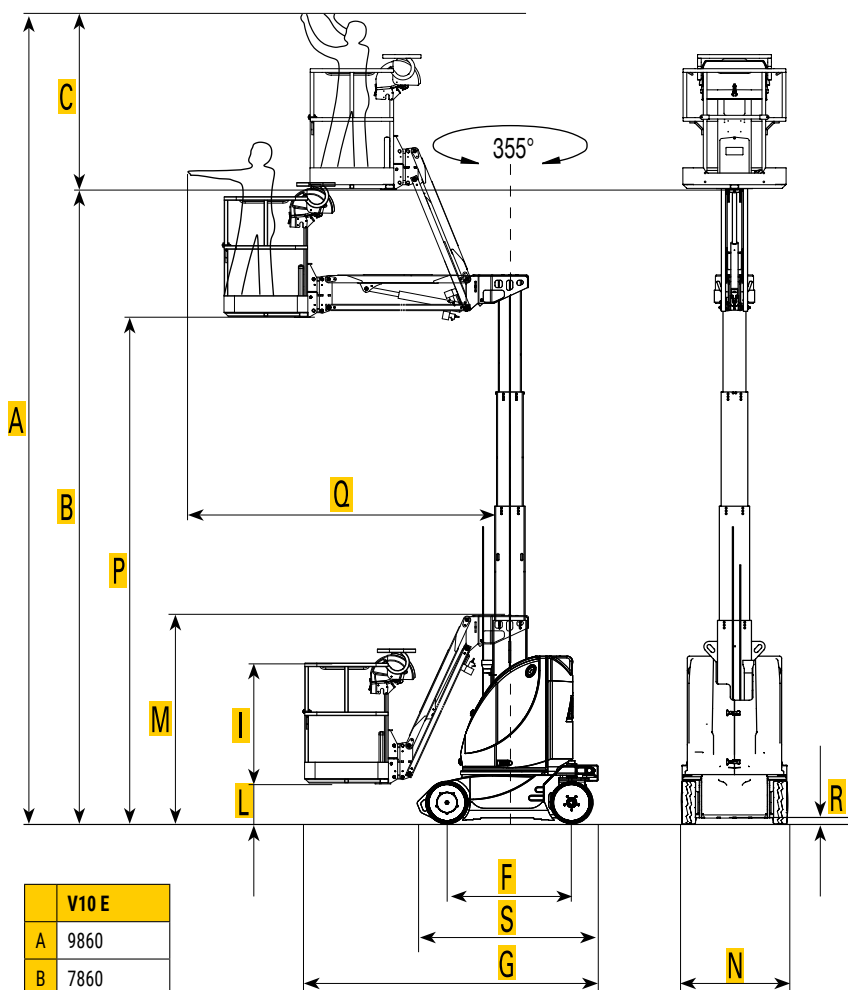

V10 E	
A	9860
B	7860
C	2000
F	1190
G	2800
I	1100
L	440
M	1990
N	998
P	6640
Q	3300
R	55
S	1730

TECHNICAL SPECIFICATIONS		V10 E
Total capacity/ N. persons	kg	200 / 2-1*
Max. working height / drivable up to max. height	m	9.8
Max. Lateral outreach	m	3.3
Turret rotation	°	355°
Rear overhang	cm	10
Platform size	mm	800x990
Power supply	-	electric motors
Battery	V/Ah	24/280
Battery charger	HFV/A	24/25
Drive speed (fast/safety)	km/h	6/0.6
Inclination (longitudinal/trasv.)	°	2/2
Gradeability	%	25
Inside/outside turning radius	m	0.28 / 1.23
Tyres size/type "Cushion Soft System" Non-marking tyres	mm	Ø 406x127
Total weight	kg	2770

\* External use

Tigieffe Srl follows a policy of continuous product improvement. Photographs used may represent version including accessories and options. Specifications are indicative and subject to change without notice. Some accessories or national standards may result in a weight increase. Technical specifications may vary according to national standards or in addition of optional version.



Dealer

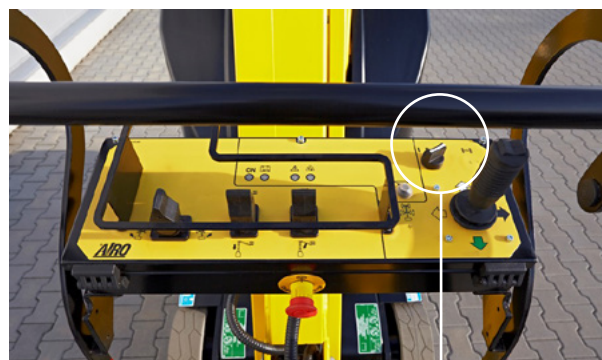

- Simple and ergonomic controls
- Joystick for each movement
- Displacement speed selector



## Standard Version

- Electric drive with A.C. motors
- Proportional controls
- Jib with 3.3m lateral outreach
- Load limiter on platform
- SENTINEL Secondary guarding device with LED flashing lights and acoustic alarm
- 230 V electric line predisposition on the platform
- Centralized battery topping via electric pump
- Acoustic and visual movement alarm
- Horn, voltmeter, hourmeter
- Flat battery indicator with battery protection device (automatic lifting stop)
- Tilt sensor with automatic motion stop
- Fixed pot-hole system for drive at max. height
- Diagnostic display
- Telematic connector
- EC Declaration of Conformity CEE

## Options and Accessories

- GEL/AGM battery kit 24V 247Ah (c5) with charger
- Control box protection cap
- Abs control control cover with tool tray and USB charger plug
- 230V power line on platform
- 230V power line on platform with circuit breaker
- Air/water line in platform
- Fleet management kit



**AIRO by TIGIEFFE S.r.l.**  
Via Villa Superiore, 82 - 42045 Luzzara (RE) - Italy  
Ph. +39 0522 977365 - Fax: +39 0522 977015  
info@airo.com - www.airo.com